

A Power Management System for High-Altitude Pico Balloon Radiation Monitoring Platform

Matheus B. S. Carvalho, Tawan Chryster dos Santos, Renan D. P. de Oliveira,
Alessandro G. Girardi, Paulo César C. de Aguirre, Edson Pereira and Lucas Compassi-Severo

Computer Architecture and Microelectronics Group - GAMA

Federal University of Pampa (UNIPAMPA)

Alegrete, RS, Brasil

eng.eletric.matheus@gmail.com

Abstract—The goal of this work is to describe the design of a high altitude pico balloon power management system capable of generating at least 245.03 mW of power to feed the electronic components of the pico balloon tracker. In this paper, the results of maximum power for three arrays of solar cells are presented. The objective is to characterize the load, from the testing of solar cells connected to the DC-DC converter, for the creation of a functional PCB for the DC-DC converter TPS61200. After data collection, the methodology used to obtain the results can be implemented. To validate the results, a system was created with the converter and the TPS61200, consisting of solar cell sets connected in series or in parallel to the converter.

Index Terms—pico balloon, solar cells, converters.

I. INTRODUCTION

The study of the Earth's atmosphere is very important in many areas of research, from environmental changes to health issues. The Earth's magnetic field is a natural protection against cosmic radiation. However, in South America there is the South Atlantic Anomaly (SAA) where the magnetic field is greatly reduced. The magnetic field in the SAA can be up to three times lower compared to other regions [1].

Cosmic radiation can be monitored using dose detectors, radiation sensors, and satellites. However, since the prevailing radiation changes at different altitudes, high altitude balloons could be used for this monitoring. For this reason, we propose the use of pico balloons to perform this task. Pico balloons are small, lightweight balloons filled with helium or hydrogen, which have a lower density than air and provide the necessary buoyancy to lift the balloon. According to [2], they can float in the Earth's atmosphere at high altitudes, even more than 30.000 meters. Pico balloons are also commonly used in ham radio experiments to explore long-range communications and test communication links. Because they are so light, pico balloons can stay aloft for weeks or even months, depending on weather conditions and other factors. They are also relatively inexpensive to launch, making them an attractive option for researchers, scientists and hobbyists alike.

The disadvantage of pico balloon experiments is their reduced payload, which is generally limited to about 20 g. Therefore, all circuits should be carefully designed to meet the weight requirements. This limitation also makes the development of the power management system (PMS) a major

challenge, since it is not possible to use any type of batteries on board.

Based on article [3], which refers to a system with an automatic starting boost converter that is powered by a low voltage thermoelectric generator. And based on article [4], which refers to boost converters that are powered by solar, thermal and vibration sources, a boost converter system powered by solar cells was proposed.

In this work we have analyzed some strategies to design the PMS considering the implementation of pico balloon platforms. The proposed system consists of an array of small photovoltaic cells and a DC-DC converter capable of providing a regulated 3.3 V to power the electronic circuits on board.

Among the DC-DC converters found in the literature. The converters discussed in this paper were chosen due to their voltage and power ranges suitable for the project, as they manage to keep their output voltages at 3.3 V.

II. POWER MANAGEMENT SYSTEM

This section presents the development of the power management system for the high-altitude tracker of the Minuano project. The Minuano project is inspired by the Amateur Radio (Ham Radio) Pico balloon experiments, an international research effort that allows hobbyists to develop small and lightweight RF radio trackers that can fly very long periods and communicate over long distances. In these experiments the tracker circuit includes a GPS receiver to maintain its position and signal synchronization, some sensors (such as temperature, pressure and brightness luminance sensors), a microcontroller (MCU), a power management unit and a RF transmitter. To enable long distance communication with very low transmission power, the MCU and RF transmitter should implement the WSPR (Weak Signal Propagation Reporter) protocol to transmit a standard message and telemetry data at a very low data rate.

The main goal of the Minuano project is to use a pico balloon to assess radiation levels and their effects on semi-conductors at an altitude of 13 to 15 km, which is very close to the altitude at which commercial aircraft fly. Fig. 1 shows the block diagram of the proposed tracker. The RF transmitter consists of a 20-dipole (an enameled wireline that connects the

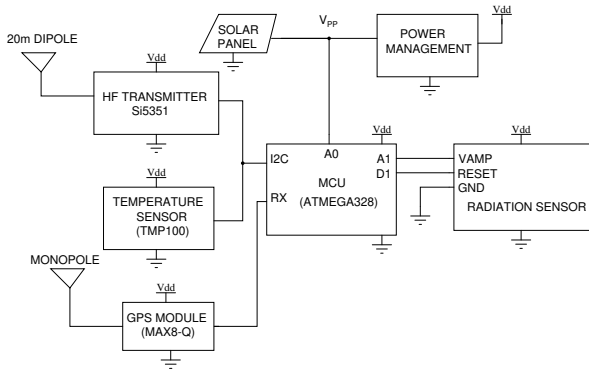

Fig. 1. Pico balloon tracker of the Minuano project

balloon to the tracker) and a HF transmitter implemented with a Si5351 chip. As sensors, the tracker includes a GPS module (U-blox MAX8-Q), a temperature sensor (TMP100), and a custom radiation sensor under development. All sensor acquisition and communication protocol processing is performed by an Atmega 328 MCU. The energy to power the tracker is generated by photovoltaic solar cells and conditioned by the power management unit.

The power management system integrated into the pico balloon tracker should provide a regulated supply voltage for all circuits in the proposed tracker. Since each component requires a certain amount of power for its operation, the first step of this work was to analyze the power budget considering all the components shown in Fig. 1. Table I summarizes the estimation of the power budget, taking into account a continuous operation with GPS acquisition at 1 Hz and the temperature prevailing at the height of the tracker (range from $-60\text{ }^{\circ}\text{C}$ to $-40\text{ }^{\circ}\text{C}$). It was also considered that during cold start the MCU, the GPS module and the temperature sensor are activated, while the RF transmitter and the radiation sensor are disabled.

As can be seen in Table I, the PMS should be able to generate a continuous power of 245.03 mW, which results in an average current of 74.25 mA for a regulated voltage of 3.3 V. To meet these requirements, the photovoltaic solar cells and DC-DC converters are analyzed in the following sections.

TABLE I
POWERS BUDGET OF THE TRACKER FOR THE MINUANO PROJECT

Component	Part	Power (mW)	I_{VDD} (mA@3.3 V)
GPS Receiver	Max8-Q	97.35	29.50
RF Transmitter	Si5351	79.86	24.20
Radiation Sensor	Customized	50.00*	15.15*
MCU (4MHz clock)	Atmega 328	17.16	5.20
Temperature Sensor	TMP100	0.66	0.20
Total		245.03	74.25

* Estimated power consumption.

TABLE II
VALUES OF SOLAR CELL SETS

Model	V_p (V)	I_p (A)	MPPT (mW)	Area (mm^2)	Mass (g)	R (Ω)
1P1S	0.36	0.1097	39.71	988	0.5	3.3
1P4S	1.39	0.1158	161.00	3952	2	12
2P4S	1.66	0.1785	296.30	7904	4	9.3
2P5S	1.84	0.1840	338.60	9880	5	10

III. ANALYSIS OF THE PHOTOVOLTAIC CELL

A PV cell can be considered as an energy transducer that converts solar energy into electrical energy. In other works the PV cell is used to harvest energy from the environment to provide energy to the electronic circuits. The performance of a PV cell depends on various factors, such as the efficiency of the cells, the angle of inclination relative to the sun, and the ambient temperature, among others.

Since solar energy is the only energy source of the tracking system, it works only during the sunshine period. The inclination of the PV cell with respect to the sun should be considered to maximize the operating time. When an array of solar cells is used, the multi-side angular configuration presents better results as it is possible to generate energy even when the sun is at a lower angle on the horizon [5].

However, in this work the tracker is tied to the balloon by the enameled wireline of the HF antenna so that it can rotate freely about its own axis. Using an angular PV cell array requires some additional electronic circuitry to switch the array cell and choose the correct generation side. It also increases the size and mass of the PMS. Based on this assumption and to obtain a straightforward implementation, we have opted for a single-sided planar configuration.

According to [6], it is possible to write the relationship between the output current, I_{PANEL} , and the internal currents of the photovoltaic cell.

In this work, we used polycrystalline silicon PV cells with a size of 52 mm x 19 mm. These cells are designed to provide an open circuit voltage of about 0.5 V, and this cell model was specified by the manufacturer to have a maximum power of about 40 mW. We tested some combinations of series and parallel associations of PV cells to estimate the power generation capacity. In this test, we changed the resistive load of the PV cell to obtain the power as a function of the load and the output voltage of the PV cell.

The maximum power point tracking (MPPT) changes depending on the cell configuration due to the higher voltage achieved by series connection. Table II summarizes the obtained results in terms of voltage, current and power. According to Table I, the target power is 245.03 mW. Thus, only the 2P4S and 2P5S provide higher output power than the required one. It is also important to analyze the effect of the weight of the solar cells, which are 4 g and 5 g in the 2P4S and 2P5S configurations, respectively.

IV. ANALYSIS OF THE DC-DC CONVERTER

DC-DC converters are a type of electronic converters that employ switched inductors or capacitors to convert a DC

voltage level to another, with reduced losses. These converters are commonly used in electronic equipment to power devices and circuits that require a different voltage level than the one provided by the main power supply.

In this work, the DC-DC converter is used to match the voltage generated by the solar cell to the supply voltage of the tracker, in this case, a voltage of 3.3 V. To maximize the power transfer from the solar cells to the DC-DC converter, it is necessary that the input impedance of the DC-DC converter is dynamically adjusted to operate at the maximum power point (MPP). If the solar cell generates a voltage lower than the 3.3 V, the DC-DC converter should operate as a boost step-up converter.

In this work, each cell has an open circuit voltage of 0.5 V. Thus, depending on the number of cells connected in series, the voltage may be lower or higher than 3.3 V. When V_P is higher than 3.3 V, a linear regulator can be used to replace the DC-DC converter, but its efficiency is greatly reduced at higher voltages. Therefore, we have adopted the commercially available integrated DC-DC converter models. The models TPS61097A and TPS61200 were analyzed based on output power and required input voltage.

A. TPS61097A DC-DC IC

The TPS61097A integrated circuit is a DC-DC converter with a wide range of applications. According to the TPS61097A datasheet [7], the circuit provides an energy solution for devices powered by solar cells. The TPS61097A has a voltage ratio that determines the output current: the higher the voltage ratio, the higher the output current.

Fig. 2 shows the typical application circuit of the TPS61097A converter, which requires an inductor L_1 and two capacitors C_1 and C_2 . To allow the DC-DC characterization we prepared and fabricated our own printed circuit board using EasyEDA software and an LPKF milling machine.

After the printed circuit board is fabricated, the DC-DC converter is characterized to verify the required input voltage levels. A triangular curve is generated with a signal generator, and a current drive is used to generate a higher power copy of this signal. This signal is applied to the input of the DC-DC converter. A resistive load is added to the output and the signals are measured with an oscilloscope. It was possible to achieve the output voltage level of 3.31 V for a load of 79 Ω , reaching a power of 138.6848 mW, when the input voltage is higher than 1.84 V, as shown in Fig. 3. Thus being insufficient power for the Minuano project.

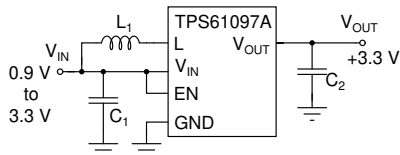

Fig. 2. TPS61097A typical circuit. Adapted by [7].

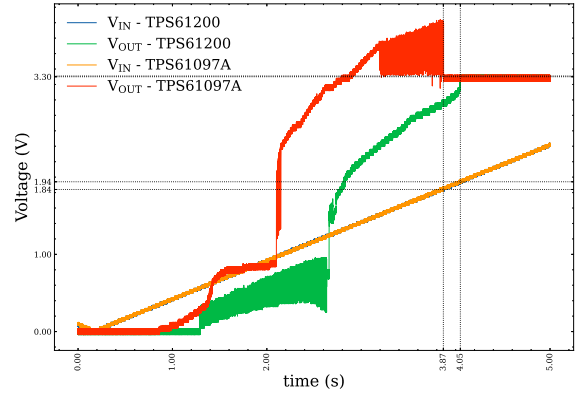

Fig. 3. TPS61097A and TPS61200 Oscilloscope Measurements.

B. TPS61200 DC-DC IC

The TPS61200 DC-DC converter can provide a power supply for devices powered by a solar cell because it is based on a fixed frequency where pulse width modulation (PWM) is controlled as it uses synchronous rectification to increase efficiency [8].

The converter can be configured to switch at a specific frequency or operate in energy saving mode to keep efficiency high when load current tends to increase. Power saving mode can be turned off and the current can be limited to an average of 1.5 A. This converter has years of flight heritage, since it is often used in commercial weather radiosondes.

The output voltage can be controlled by an off-chip resistive divider. Fig. 4 shows the typical application circuit of the TPS61200 converter, the input operating voltage is between 0.3 V and 5.5 V.

The TPS6120 IC has been characterized in a similar manner as stated for the TPS61097A IC. It has been tested with a load of 36.3 Ω . The measurement results with 36.3 Ω is shown in Fig. 3. The DC-DC converter was able to supply 3.3 V to the load with a power of 300 mW and required an input voltage of 1.94 V. Thus concluding that the load 36.3 Ω is adequate for this converter, due to the power of the Minuano project being reached.

V. PMS EXPERIMENTAL RESULTS

Based on the previous analysis, the PMS was tested by connecting the PV cells to the DC-DC and the DC-DC to the load, as shown in Fig. 5 (a) for the TPS61097A and

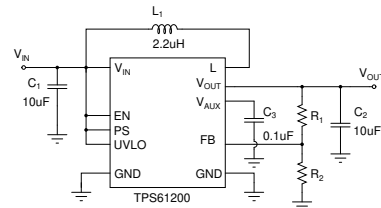

Fig. 4. TPS61200 typical circuit. Adapted by [8]

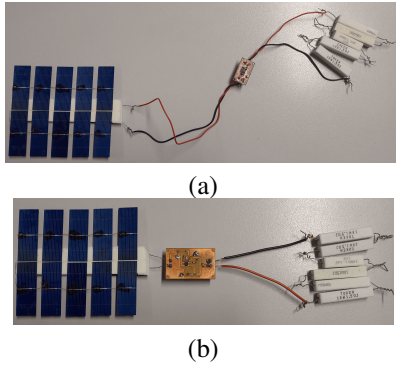

Fig. 5. TPS61097A (a) and TPS61200 (b) converters connected to solar cell array

Fig. 5 (b) for the TPS61200. These measurements were made on a cloudless day between 4:00 pm and 5:00 pm, with a temperature of 32 °C.

For the system with the 2P5S solar cell set connected to the TPS61097A converters, as shown in Fig. 5 (a), the solar cells generated 338.6 mW, according to Table III, while the converter generated 179.41 mW at a load of 59.6 Ω, reaching 3.27 V, having an efficiency of 52.99%, making it an insufficient system, since the system as a whole has a mass of 9 g, without considering the values of the loads.

Fig. 6 presents the test of the solar cells that are connected to the TPS61097A converter, with an arrangement of ten solar cells in series, generating a voltage of 2.659 V. At the output of the converter, with a load of 64 Ω, it reached a voltage of 3.283 V for a power of 168.41 mW.

For the system with the 2P5S solar cell array connected to the TPS61200 converters (Fig. 5 (b)), the solar cells generated 338.6 mW (Table III), while the system with the converter generated 284.61 mW at a load of 37.8 Ω, which is suitable for the Minuano project and has an efficiency of 84.05%. This system has a mass of 12 g, not including the load.

VI. CONCLUSIONS

In this paper, a power management system was presented to supply energy to the tracker of the Minuano project. It

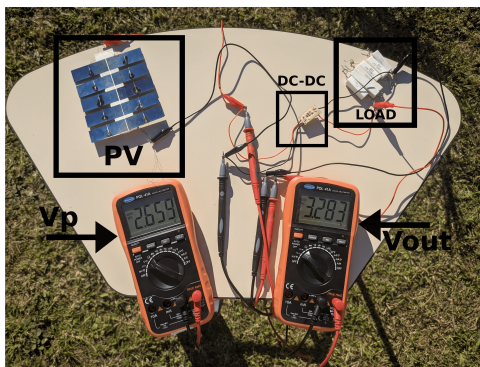

Fig. 6. TPS61097A converter connected to the solar cell array and resistive load of 64 Ω.

TABLE III
SYSTEMS POWER GENERATION DATA

Model	P_P (mW)	Converter	V_C (V)	I_C (A)	MPPT (mW)	R (Ω)
2P4S	338.6	TPS61097A	3.27	0.054865772	179.411074	59.6
2P5S	338.6	TPS61200	3.28	0.086772487	284.613757	37.8

consists of the association of some PV cells and an integrated DC-DC converter. The 2P4S and 2P5S PV cells association were capable of delivering a maximum power of 296 mW and 338 mW, respectively, sufficient to provide the 245 mW required by the electronic circuits of the Minuano project. Two step-up DC-DC converters were analyzed and tested. The TPS61200 IC was able to generate 338.60 mW of power with an efficiency of 84.05%. In addition, the TPS61097A converter generated 179.41 mW with an efficiency of 52.94% with respect to the 338.90 mW power generated by the solar cell array. With this efficiency, it was not possible to meet the requirements of the tracker components. In addition, two ICs would have to be used to meet the power requirements, increasing the mass.

The TPS61200 IC with the 2P5S PV cell array presents all the characteristics required for use as the PMS of the Minuano project. The masses of the two systems presented (Fig. 5 (a) and Fig. 5 (b)) refer to the prototype systems, with the PCBs oversized just for testing.

As future work, we intend to design the PCB of the whole tracker to validate the proposed PMS operation with all the included circuits and perform some flight tests with altitude balloons to validate the temperature and altitude tests.

REFERENCES

- [1] C. C. Finlay, C. Kloss, N. Olsen, M. D. Hammer, L. Tøffner-Clausen, A. Grayver, and A. Kuvshinov, "The chaos-7 geomagnetic field model and observed changes in the south atlantic anomaly," *Earth, Planets and Space*, vol. 72, no. 1, pp. 1–31, 2020.
- [2] D. M. Wilt, A. Haas, P. P. Jenkins, J. Lorentzen, C. Hare, D. Hernández, A. Gras, G. Martínez, J. Baker, and R. Hoheisel, "High-altitude space solar cell calibration on small balloons," in *2019 European Space Power Conference (ESPC)*, 2019, pp. 1–3.
- [3] J.-P. Im, S.-W. Wang, S.-T. Ryu, and G.-H. Cho, "A 40 mv transformer-reuse self-startup boost converter with mppt control for thermoelectric energy harvesting," *IEEE Journal of Solid-State Circuits*, vol. 47, no. 12, pp. 3055–3067, 2012.
- [4] S. Bandyopadhyay and A. P. Chandrakasan, "Platform architecture for solar, thermal, and vibration energy combining with mppt and single inductor," *IEEE Journal of Solid-State Circuits*, vol. 47, no. 9, pp. 2199–2215, 2012.
- [5] R. B. Nazmul, "Calculating optimum angle for solar panels of dhaka, bangladesh for capturing maximum irradiation," in *2017 IEEE International WIE Conference on Electrical and Computer Engineering (WIECON-ECE)*, 2017, pp. 25–28.
- [6] R. L. B. Zamparete, "High efficiency mppt switched capacitor dc-dc converter for photovoltaic energy harvesting aiming for iot applications," 2017, "Master's Dissertation, UFRGS". [Online]. Available: <http://hdl.handle.net/10183/173738>
- [7] T. Instruments, "Tps61097a-33 low-input voltage synchronous-boost converter with low quiescent current;" 2014, revised December 2014. [Online]. Available: <https://www.ti.com/lit/ds/symlink/tps61097a-33.pdf>
- [8] —, "Tps6120x low input voltage synchronous boost converter with 1.3-a switches;" 2007, revised December 2014. [Online]. Available: <https://www.ti.com/lit/ds/symlink/tps61200.pdf>